

**DÉCLARATION DES PERFORMANCES
DECLARATION OF PERFORMANCE
PRESTATIEVERKLARING
BAI001 – BAI050**

1. Produit / Product :

BAI001 – BAI050

2. Usage prévu / intended use / Voorgenomen gebruik :

Baignoire destinée à l'usage domestique
Bathtub for domestic
Badkuip voor huishoudelijk

3. Fabricant / Manufacturer / Fabrikant :

1. AURLANE 55 RUE DE LA CONDAMINE 75017 PARIS

4. Mandataire : Non applicable

5. Système(s) d'évaluation et de vérification de la constance des performances : Système 4

6a/ Norme harmonisée / Harmonised standard / Geharmoniseerde norm :

EN 14516:2015+A1:2018 — Appareils sanitaires – Baignoires
Sanitary appliances – Baths
Sanitaire uitrusting – Badkuipen

7. Performances déclarées / Declared performance / Verklaarde prestaties:

EN14516 : 2006+A1:2010

Caractéristiques Features kenmerken	Performances Performances Leistung	Specifications Specification Spesifikation
Aptitude au nettoyage / cleanability / schoonmaakgemak	Satisfait / met / voldoet	EN14516 : 2006+A1:2010
Durabilité / Durability/ Levensduur	Satisfait / met / voldoet	EN14516 : 2006+A1:2010

Les performances du produit identifié ci-dessus sont conformes aux performances déclarées.
The performance of the product identified above is in conformity with the declared performance.
De prestaties van het bovenvermelde product komen overeen met de verklaarde prestaties.

La présente déclaration de performance est établie sous la seule responsabilité du fabricant.
This declaration of performance is issued under the sole responsibility of the manufacturer.
Deze prestatieverklaring wordt opgesteld onder de uitsluitende verantwoordelijkheid van de fabrikant.

Signé au nom du fabricant / Signature / Handtekening:

Sebastien DOUMENC
Directeur Associé AURLANE
A Paris, le 01/01/2022





NETTOYAGE RÉGULIER/ REGULAR CLEANING /REGELMATIG ONDERHOUD:

Détergent au pH neutre ou vinaigre blanc dilué. Rincer abondamment.
Neutral-pH detergent or diluted white vinegar. Rinse thoroughly
Neutrale pH-reiniger of verdunde witte azijn. Grondig spoelen



**NETTOYAGE DU CALCAIRE / LIMESCALE CLEANING /
KALKAANSLAG REINIGEN:**

utiliser un chiffon doux avec du jus de citron ou du vinaigre blanc
use a soft cloth with lemon juice or white vinegar
gebruik een zachte doek met citroensap of witte azijn.



Ne jamais utiliser de nettoyeur contenant des grains de polissage, d'acétone, de chlore, d'ammoniaque (javel) ou tout autre nettoyeur agressif à base d'acide.

Never use cleaners containing polishing grains, acetone, chlorine, ammonia (bleach), or any other aggressive acid-based cleaner.

Gebruik nooit reinigingsmiddelen met polijstkorrels, aceton, chloor, ammoniak (bleekmiddel) of andere agressieve, op zuur gebaseerde reinigers

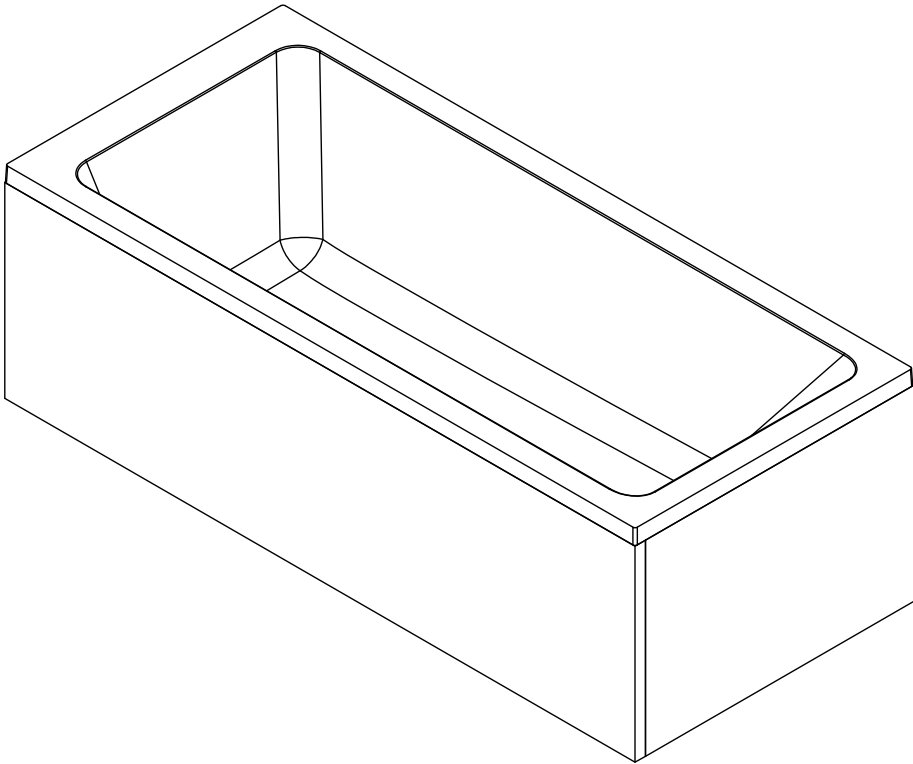

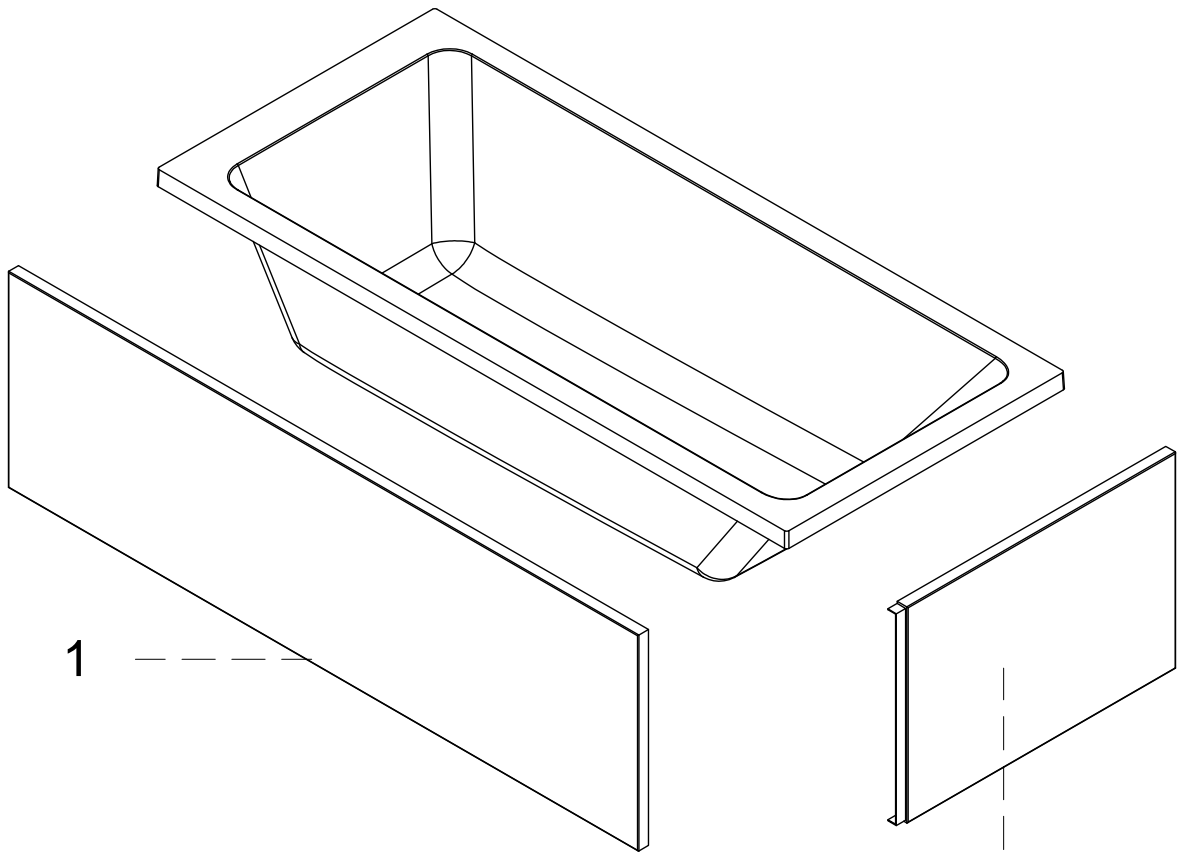

1

2

3



4



4

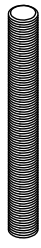
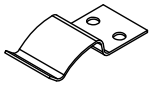

6



7

5

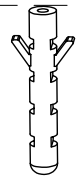

1

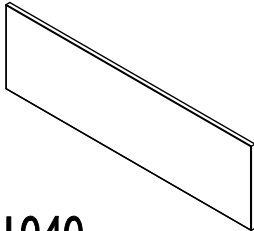

BAI040

X1

3

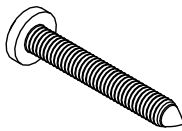

ST3.9X35

X8

4

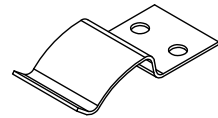

AURL2438

X8

5

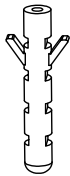

AURL2438

X8

6



ST3.9X13

X8

7



X4

2

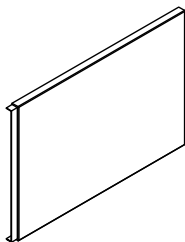

BAI041

X1

3

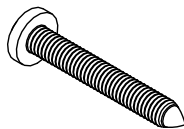

ST3.9X35

X4

4

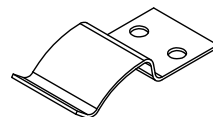

X4

5

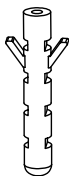

X4

6



ST3.9X13

X4

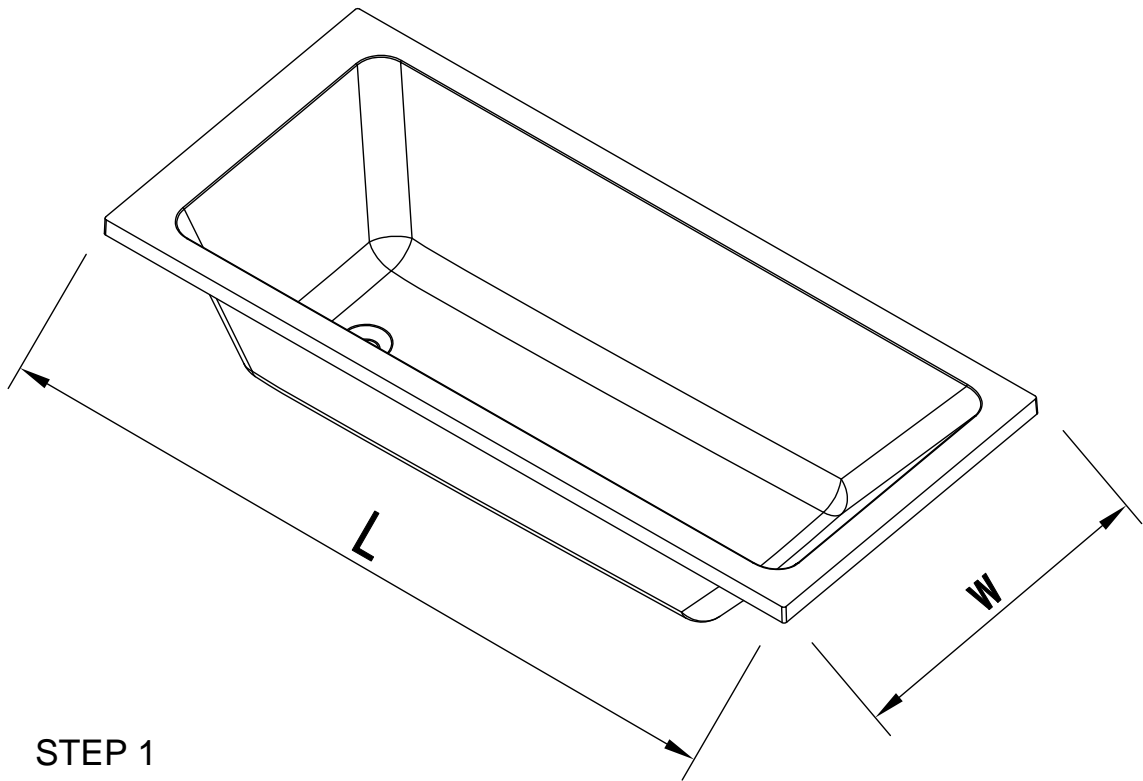

STEP 1

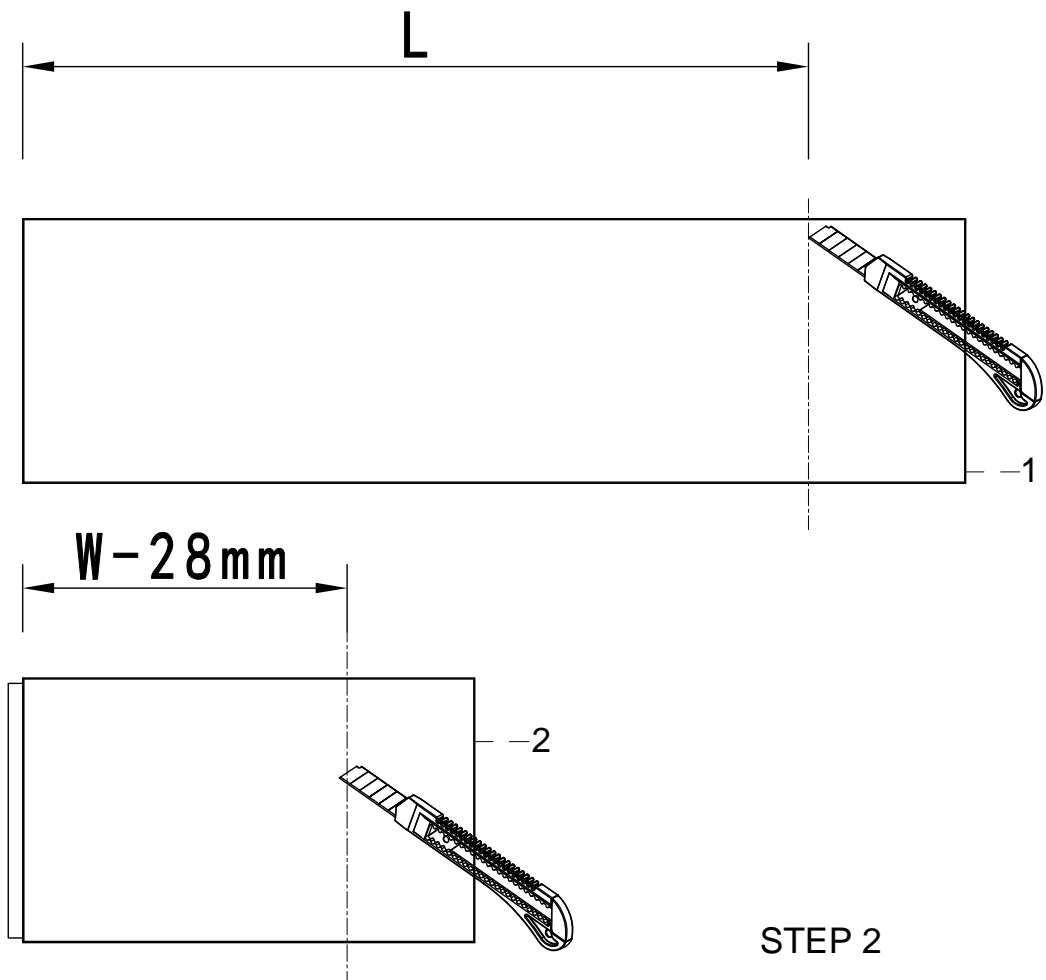

STEP 2

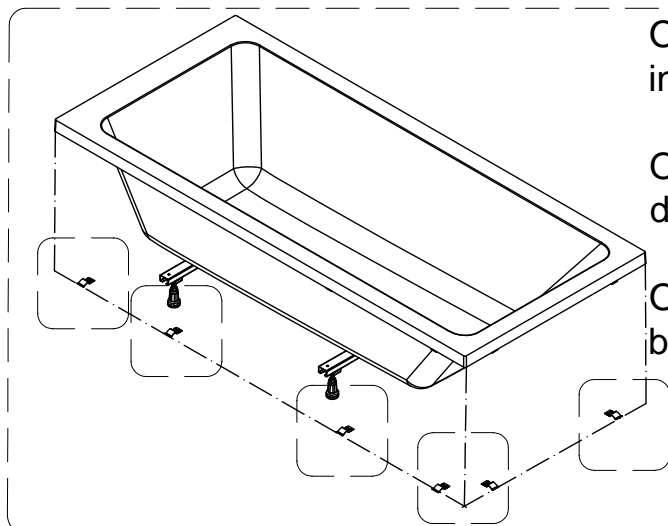
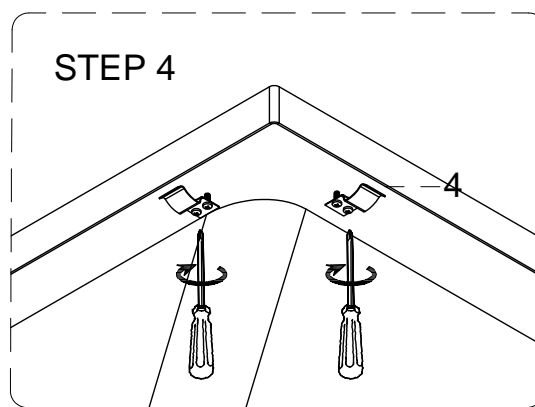
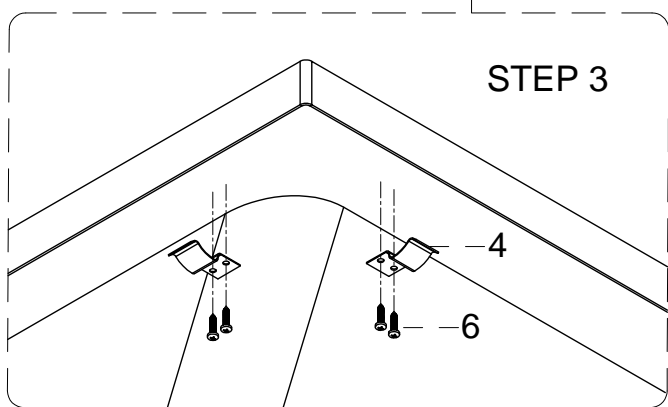
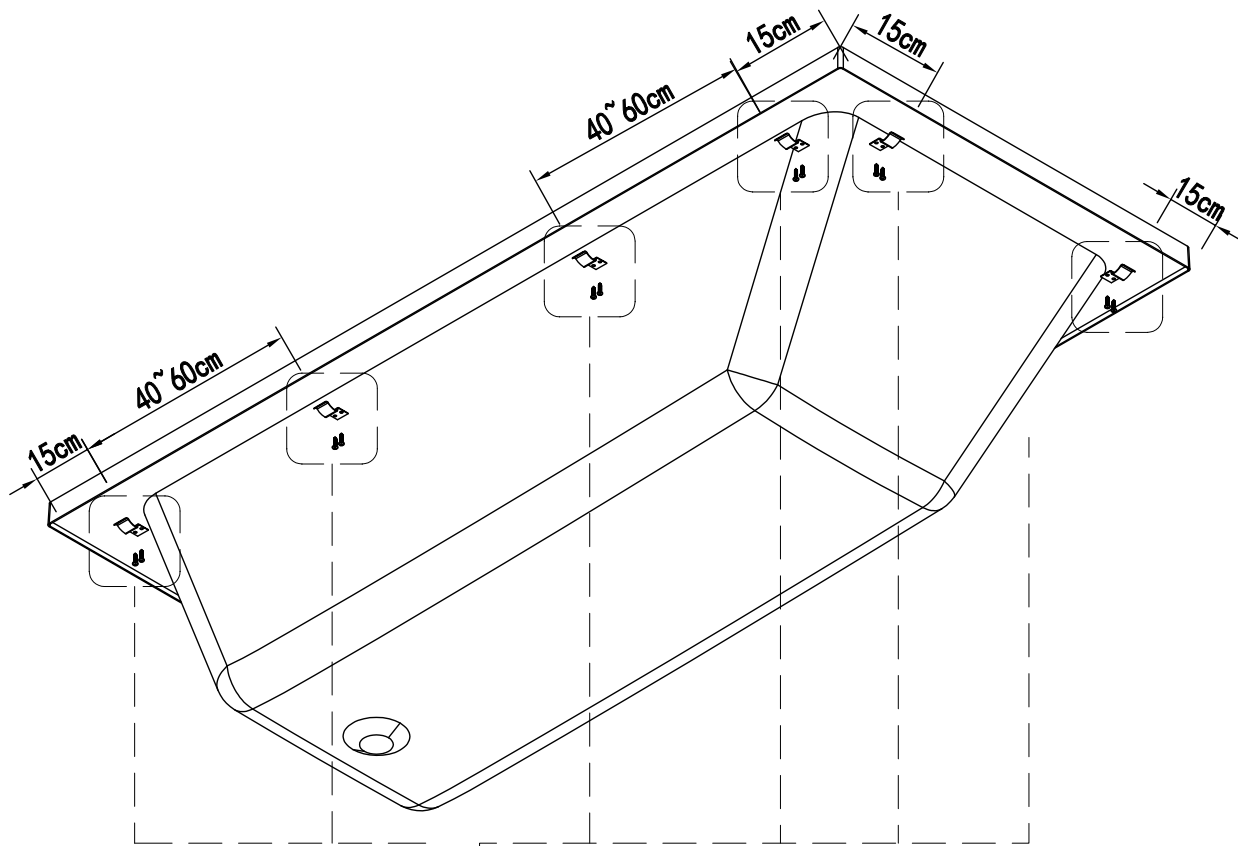

Optional: screwing the mounting brackets into the ground

Optionnel : visser l'fixations métalliques dans le sol

Optioneel: het vastschroeven van de bevestigingspoten in de grond



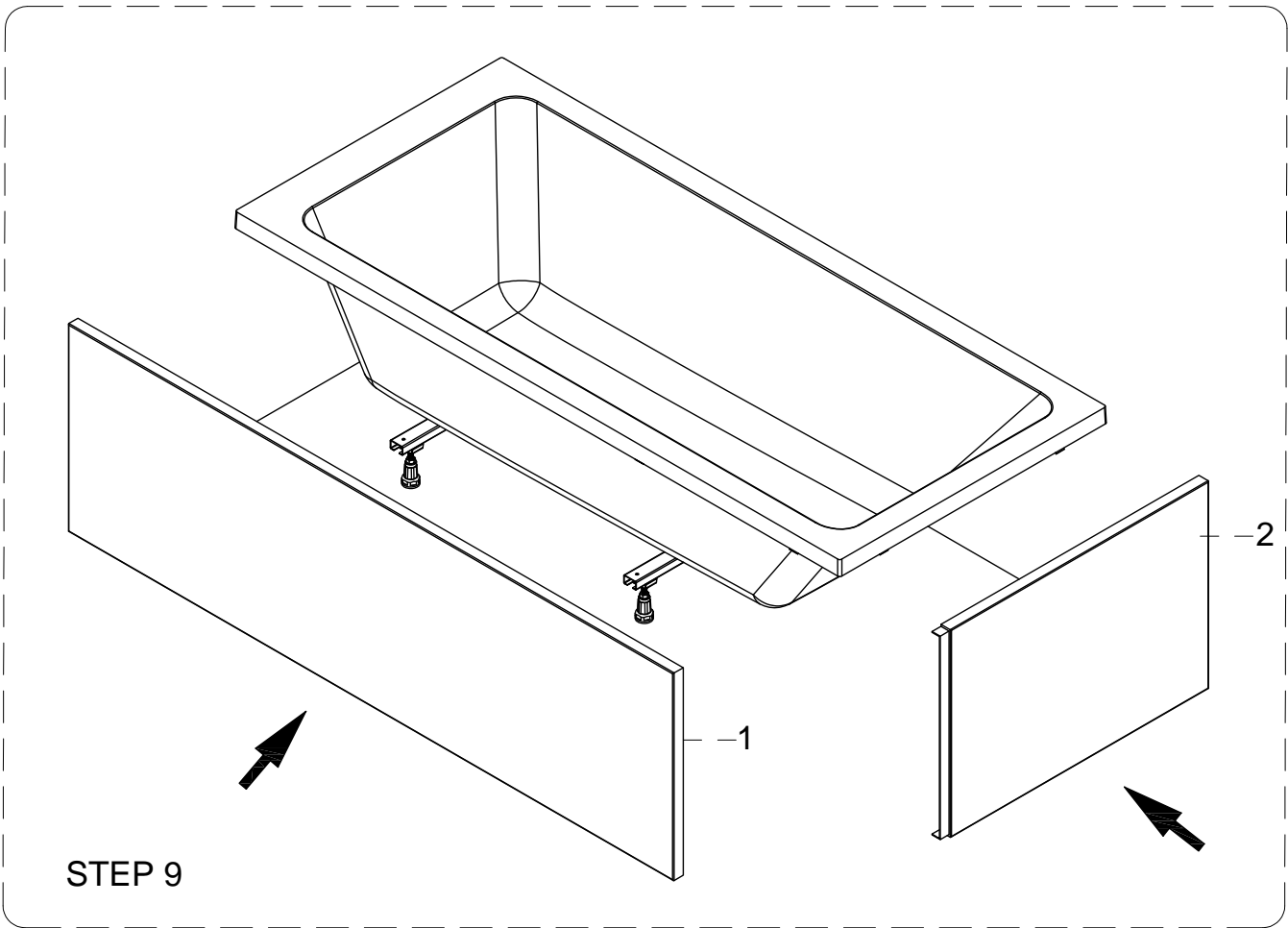

STEP 9

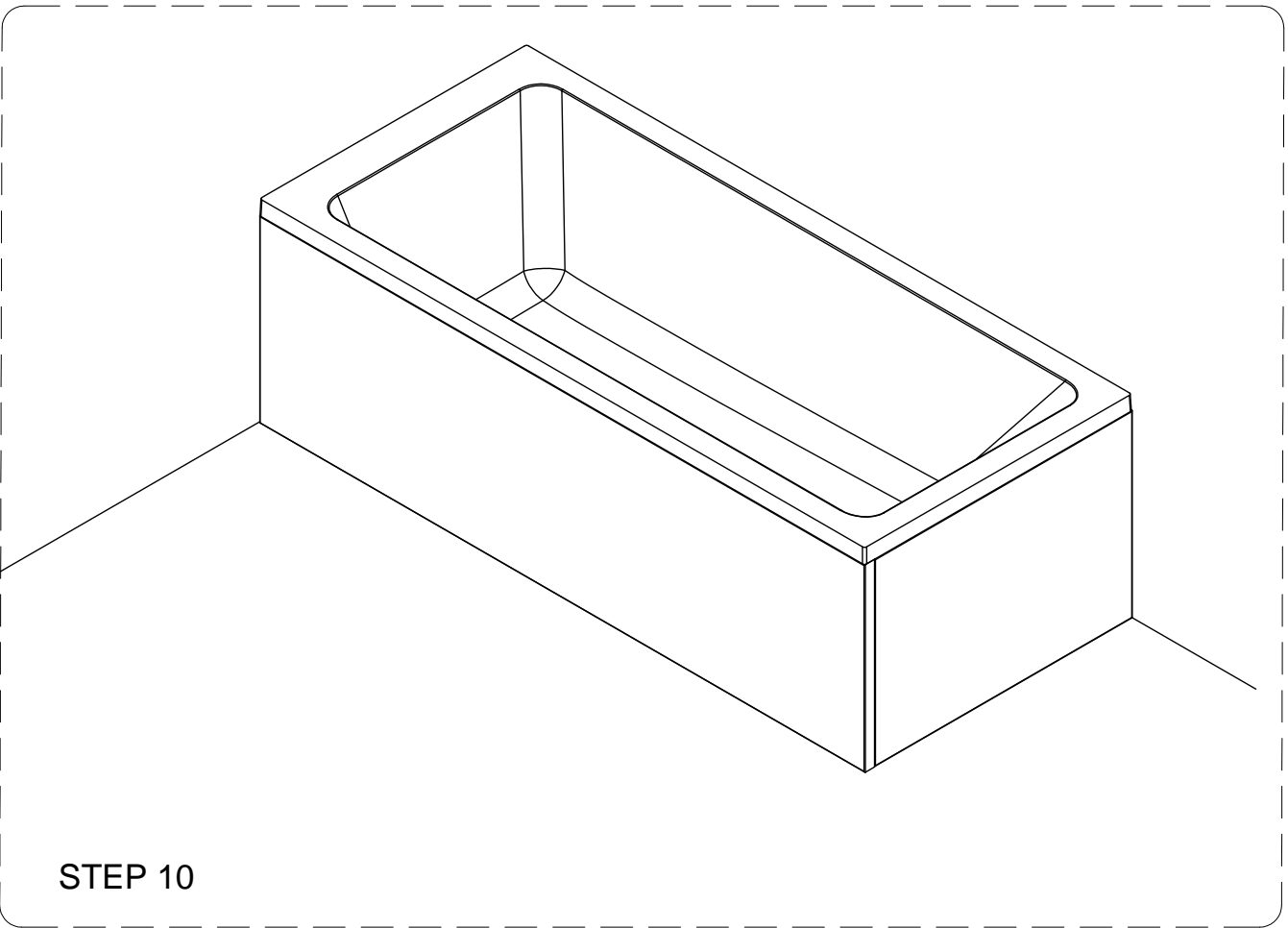

STEP 10

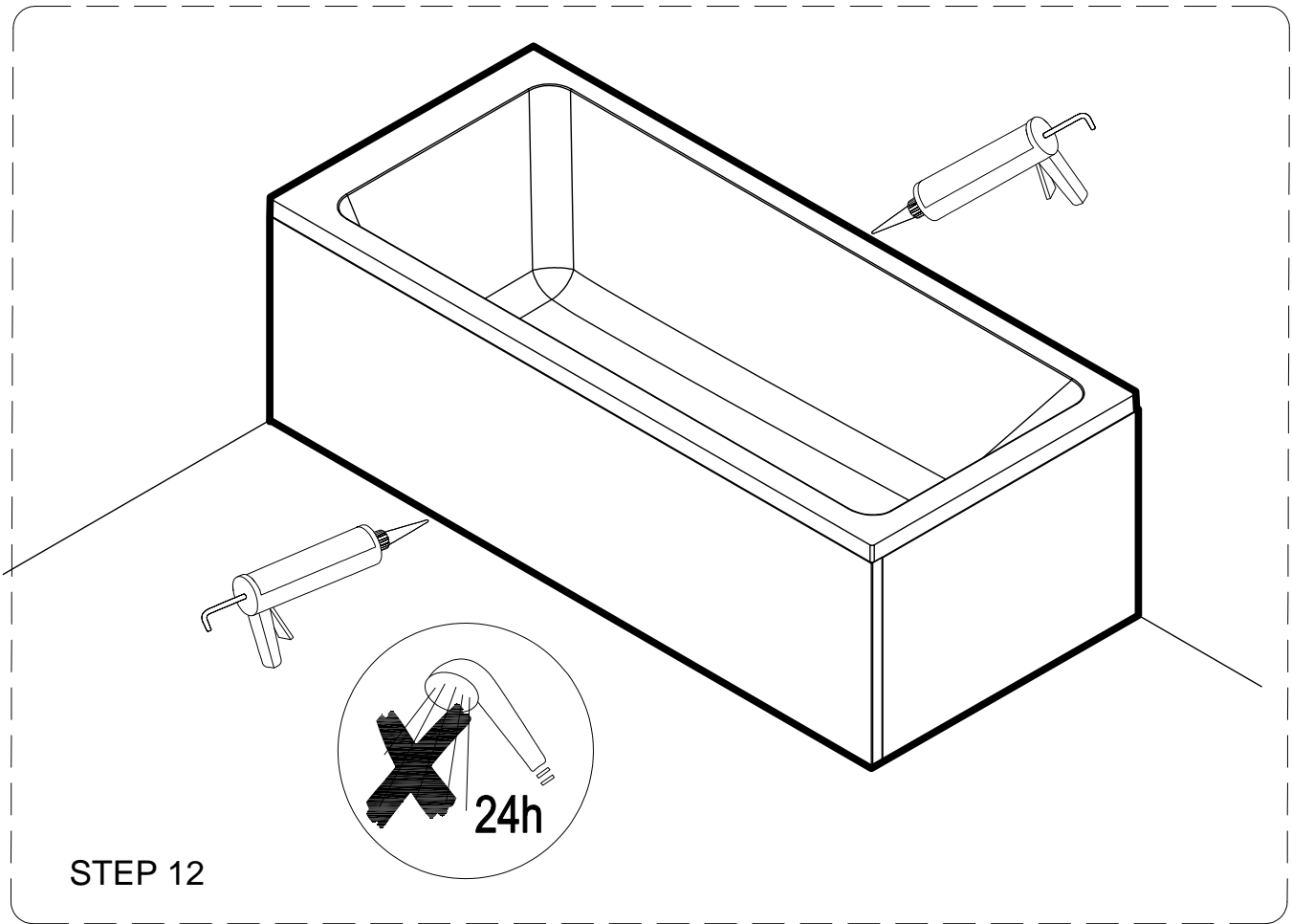

STEP 12

Optional Installation Steps

